

Dimension

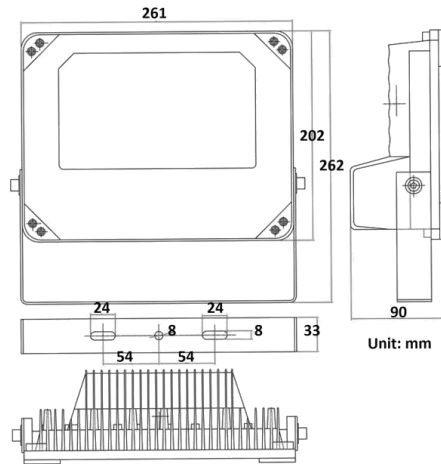

Instruction of IR Illuminator

S-LH40-IR

Models for selection

Model	Beam Angle	IR Distance (850nm)
S-LH40-15-A-IR	15°	300m
S-LH40-30-A-IR	30°	220m
S-LH40-45-A-IR	45°	130m
S-LH40-60-A-IR	60°	110m

*IR distance is tested by SONY 1/3" CCD Camera.

To achieve the distance needed, please pay attention to your camera specification and lens before purchase. It is normal phenomenon that distance may vary due to different cameras and lens.



Our product is weatherproof and dustproof. Do not modify the shape, dismantle or reconfigure the product, any inflow of water cause by which are not be responsible for warranty repair.

Please strictly follow the below instructions when install this product!

Description

- Smart uniform irradiation solution improves image quality & monitoring effect
- Accurate constant circuit drive develops excellent performance of product
- Fill light for night vision camera
- Long range IR distance at night time
- Indoor/outdoor use, all-weather use
- High integrated solution for easy installation and saving cost

Specification

Quantity of LED	40pcs high power 1W IR LED
Wavelength	850nm
Beam angle	15° - 60°
IR distance	300m-110m
Day/night switch	CDS 10-20lux ±10%
Input voltage	AC110-220V
Power consumption	< 54W
Cable length	3 core wire 70cm
Panel	Tempered glass panel
Housing	Aluminum die-casting housing
Bracket	Wall mount bracket
Working temperature	-20°C to +50°C
Protection level	IP66
Color	White
N.W	2.4kg
G.W	2.7kg
Packing dimension	290*220*140mm

Installation

1. The product includes fragile parts. Take care on every transportation steps and hold carefully, do not stress!
2. Ensure operating voltage and current are proper before installation.
3. Install the product on the holder by fixing the mount hold with screws directly.
4. Adjust the angle of product by loosening screws on bracket.
5. Link power wires tightly and make it waterproof to avoid electric shock.
6. Connect with extra power wire should make it waterproof at the same.
7. The outlet of power wire should be installed downward.
8. Don't use against any fire precaution rules during operation.
9. Installation requested professional operation and qualified personnel.
10. Connect our sales person if you need additional parts for installation.

Maintenance

1. Cut off power before maintenance.
2. Clean the glass regular to get better transmission of light.
3. Clean the housing to get well heat dissipation performance.
4. Clean by dry dishcloth, don't use water or strong corrosive solution.

Night vision pictures



Night time with IR Light



Night time without IR Light